

# Green Dragon / Zielony Smok

design Piotr Pluta 2004  
 diagram Adam Szewczyk, Piotr Pluta, Artur Biernacki, Rafał Sabat  
 e-mail pluta.piotr@gmail.com  
 web [www.origamiart.pl](http://www.origamiart.pl)

OrigamiArt™

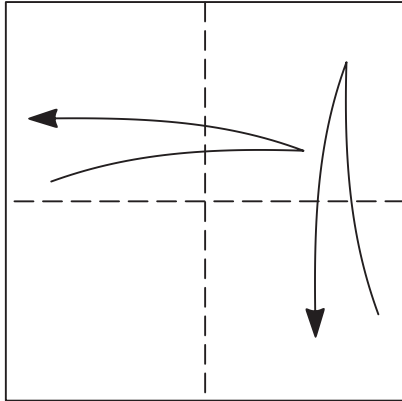

1.

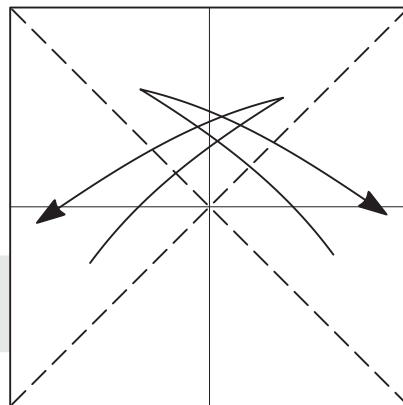

2.

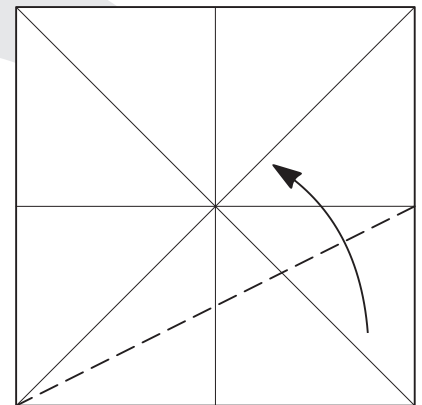

3.

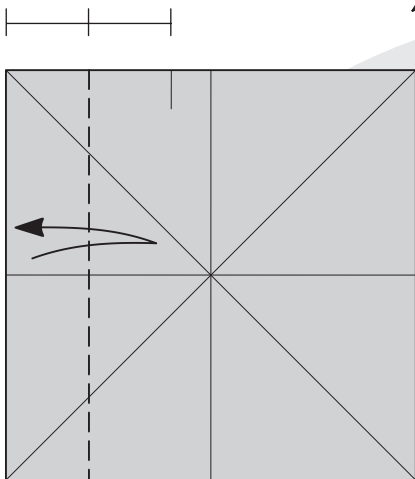

5.

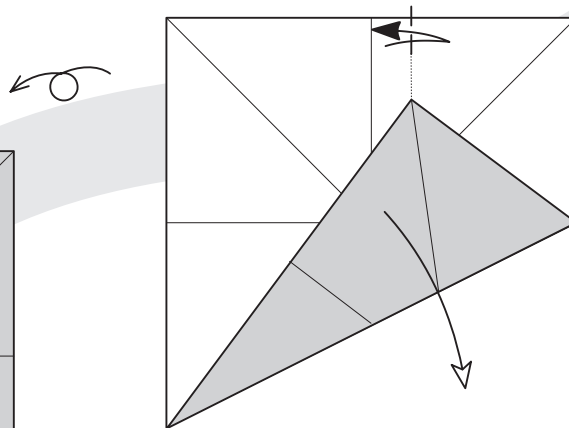

4.

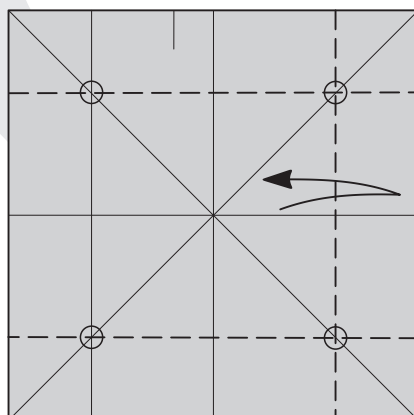

6.

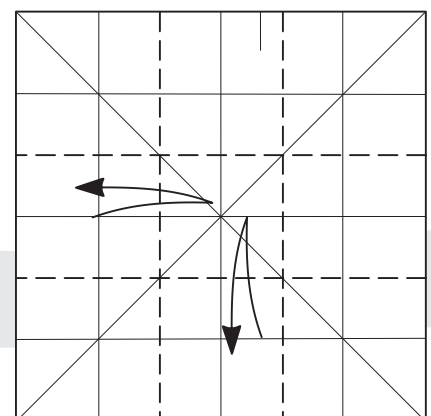

7.

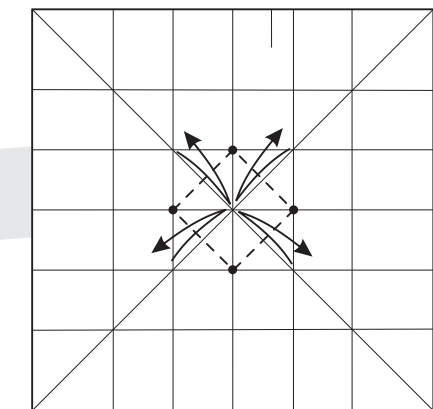

8.

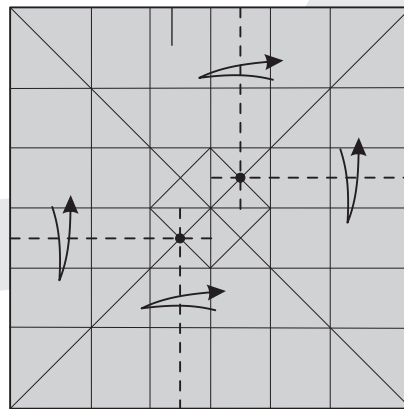

9.

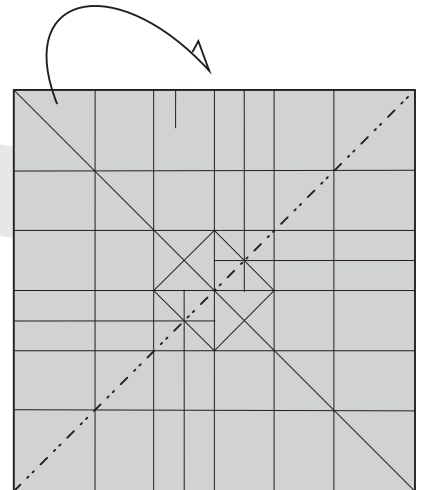

10.

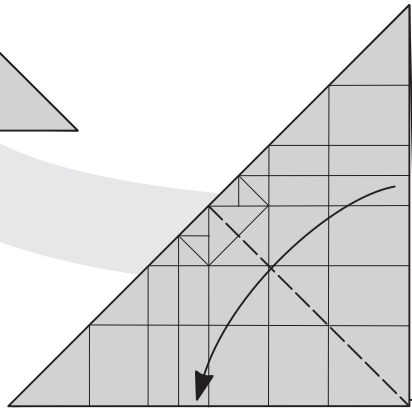

11.

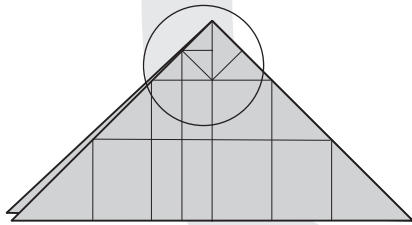

12.

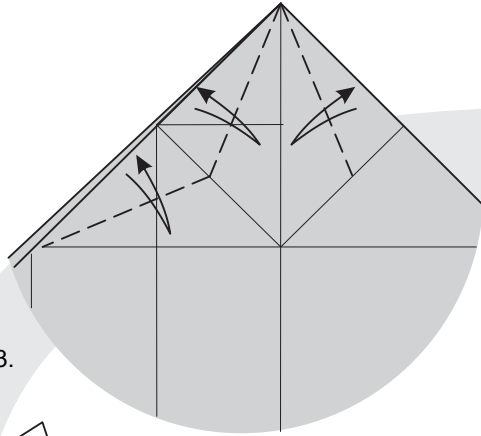

13.

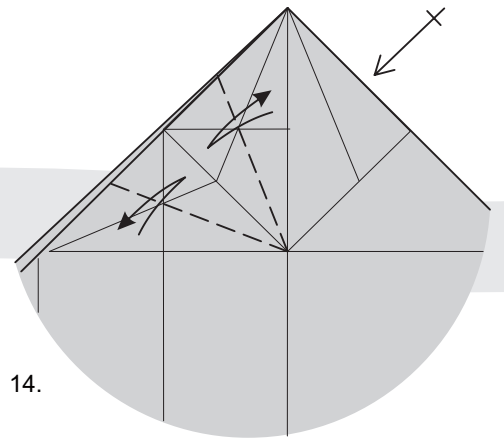

14.

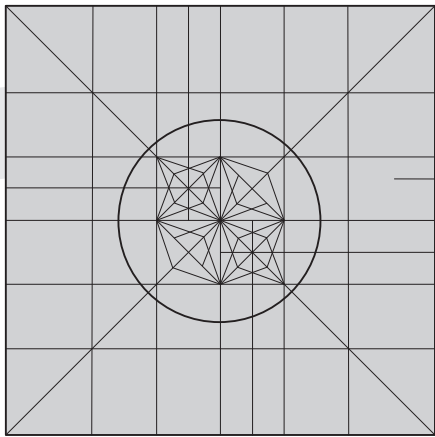

15.

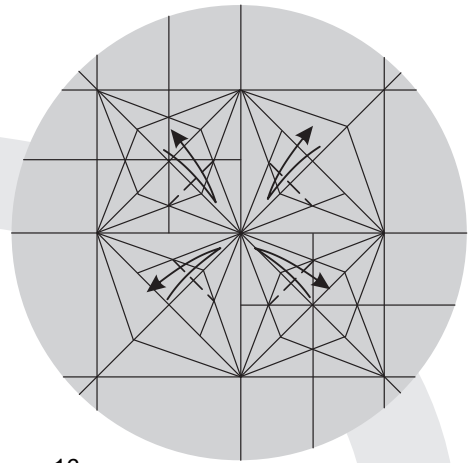

16.

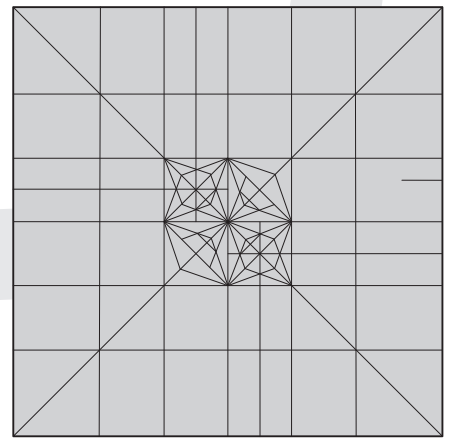

17.

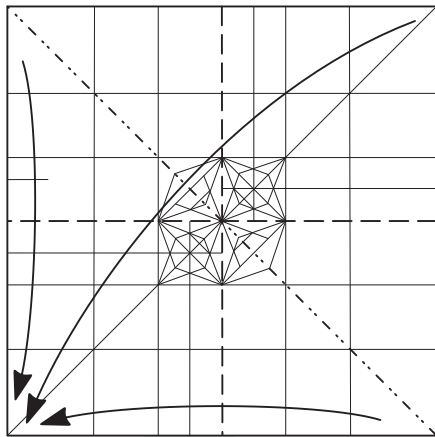

18.

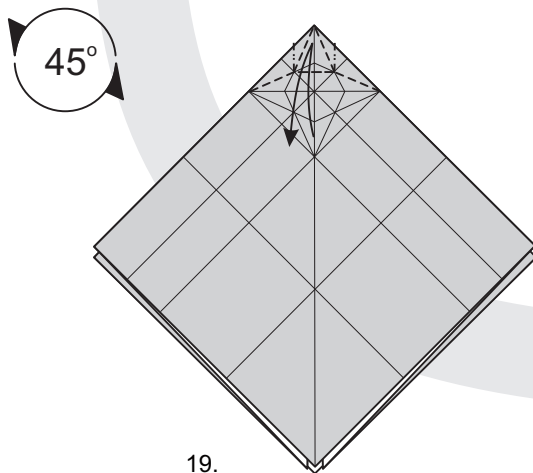

19.

Złóż i rozłóż tylko wierzchnią warstwę.  
Fold and unfold only nearer layer

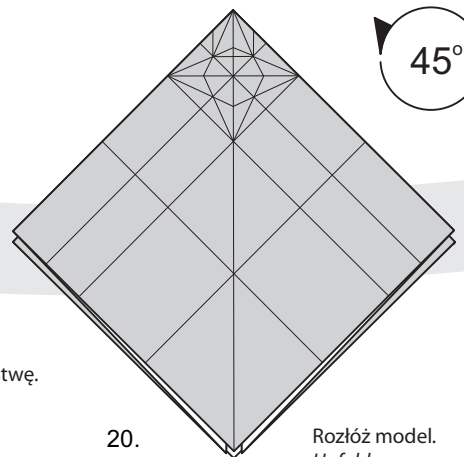

20.

Rozłóż model.  
Unfold.

25-26

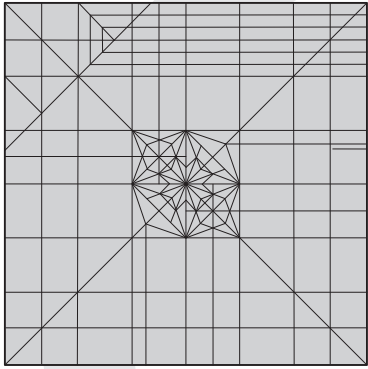

27.

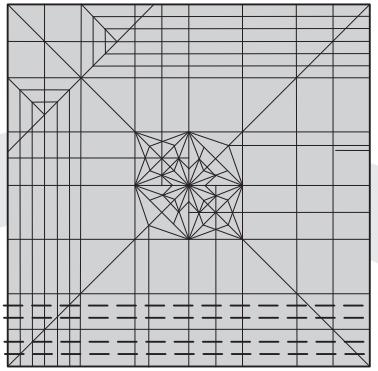

28.

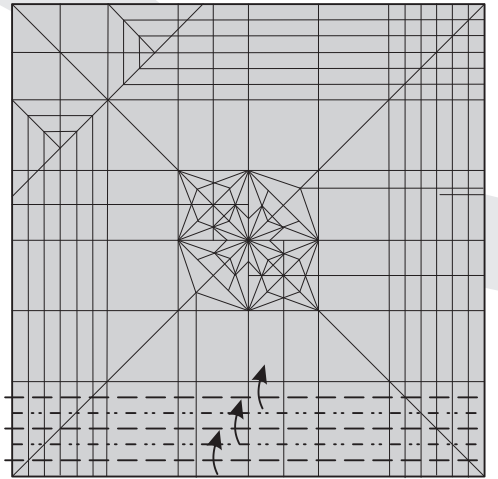

29.

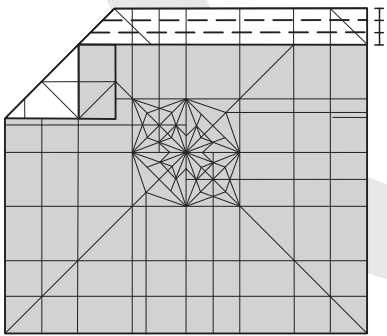

26.

Rozłóż.  
Unfold.

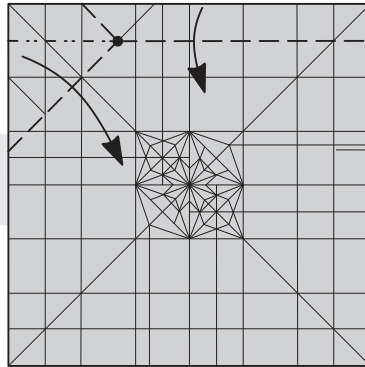

25.

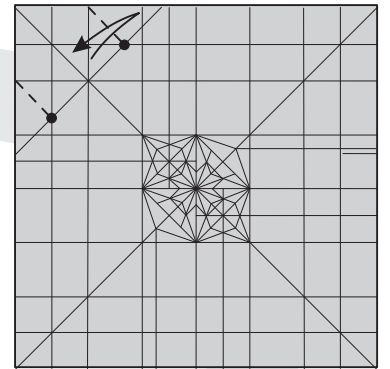

24.

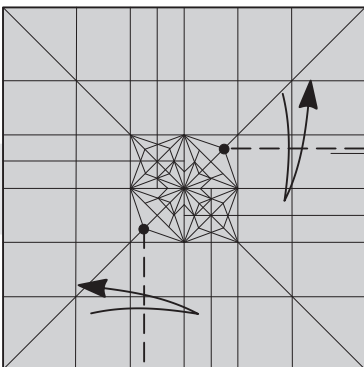

21.

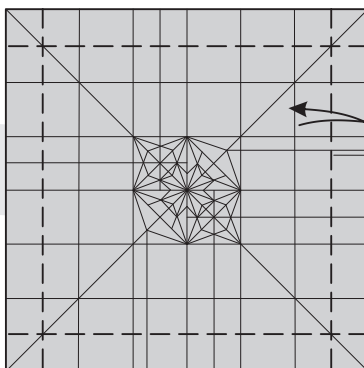

22.

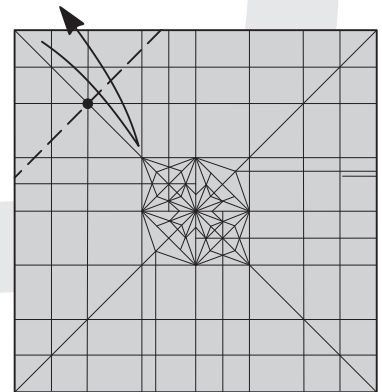

23.

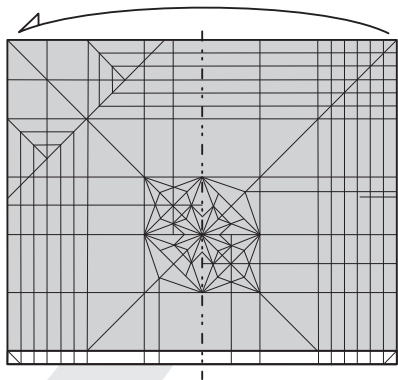

30.

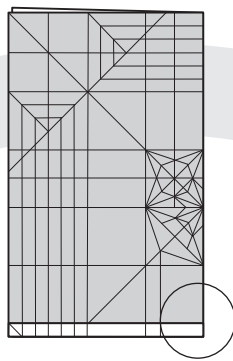

31.

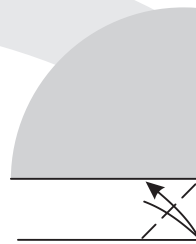

32.

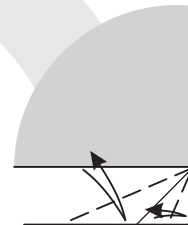

33.

Rozłóż.  
Unfold.

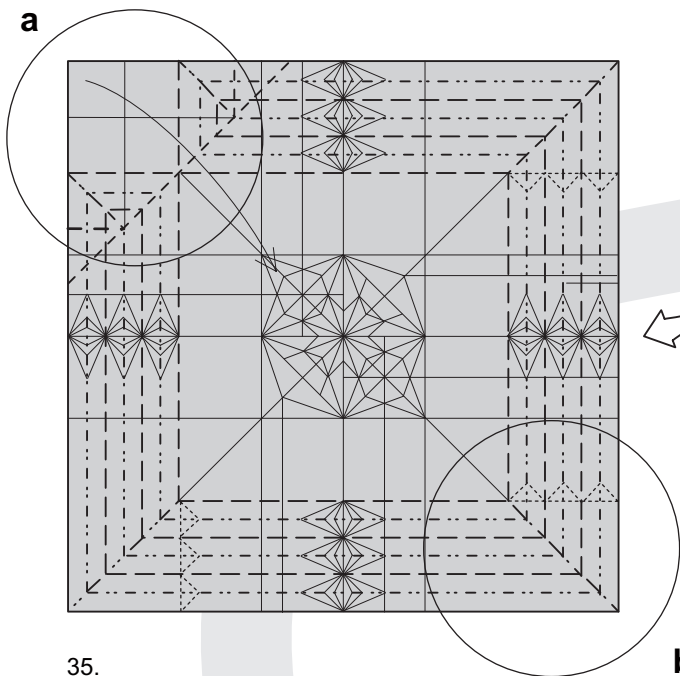
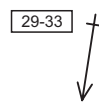

35.

Złóż jednocześnie wg linii.  
Fold the paper simultaneously  
along the crease lines.

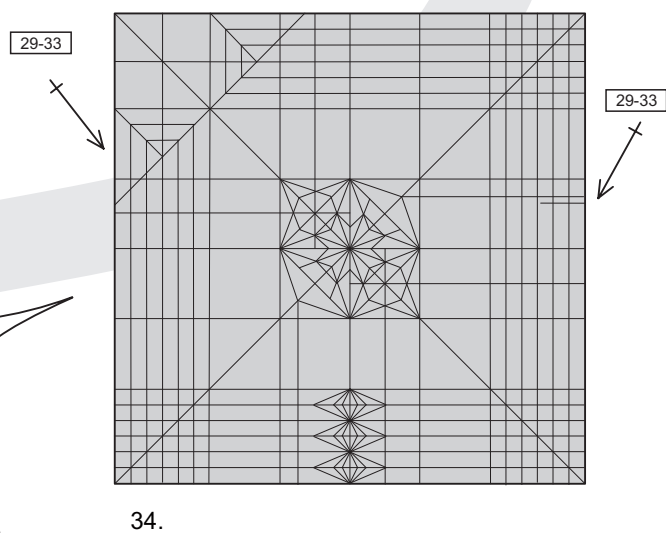

34.

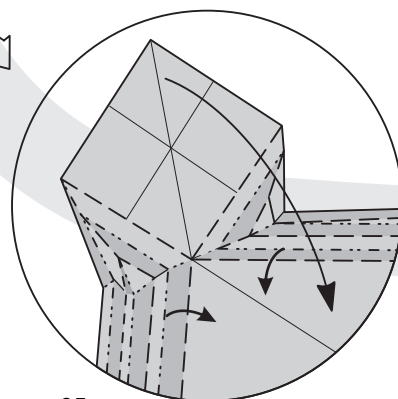

35a

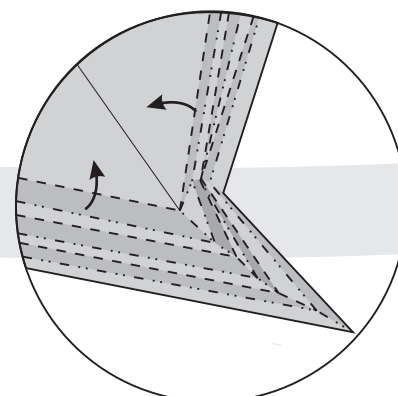

35b

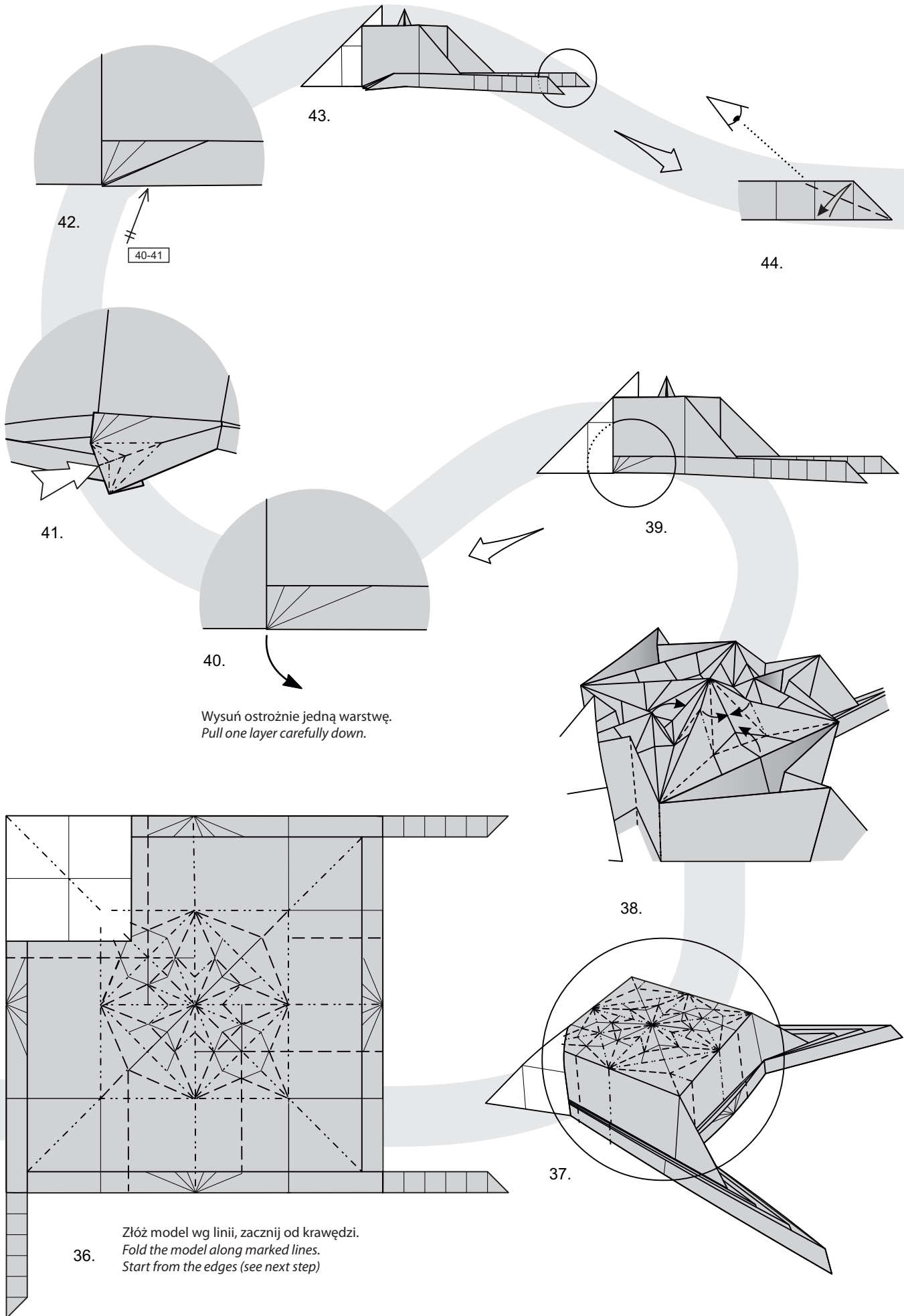

42.

40-41

43.

44.

41.

40.

39.

Wysuń ostrożnie jedną warstwę.  
Pull one layer carefully down.

38.

36.

Złóż model wg linii, zacznij od krawędzi.  
Fold the model along marked lines.  
Start from the edges (see next step)

37.

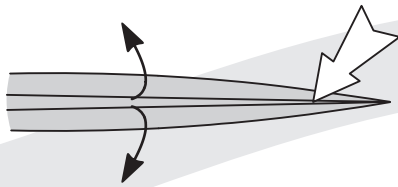

45.

Otwórz i splaszcz.  
Open and flatten.

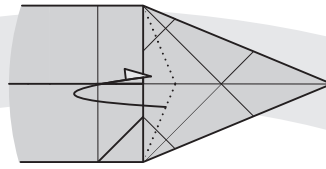

46.

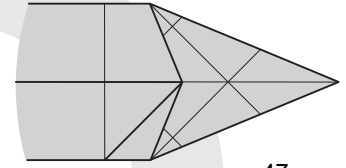

47.

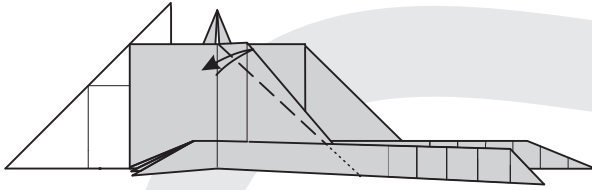

49.

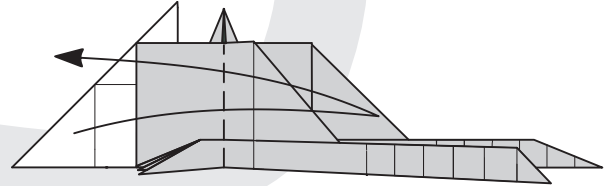

48.

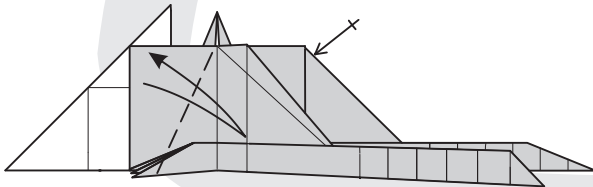

50.

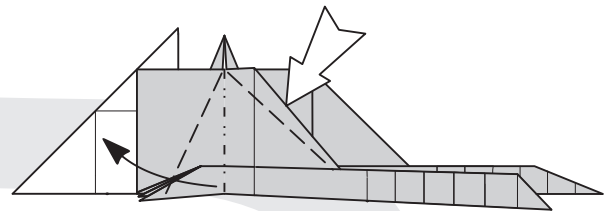

51.

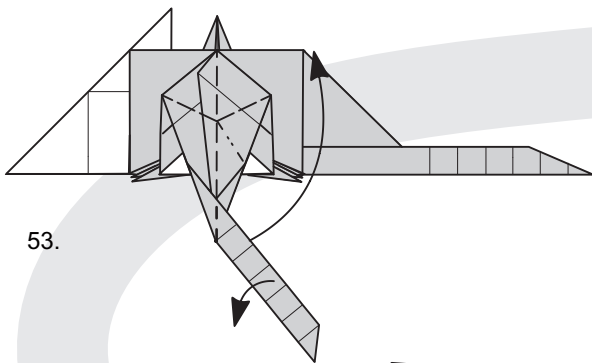

53.

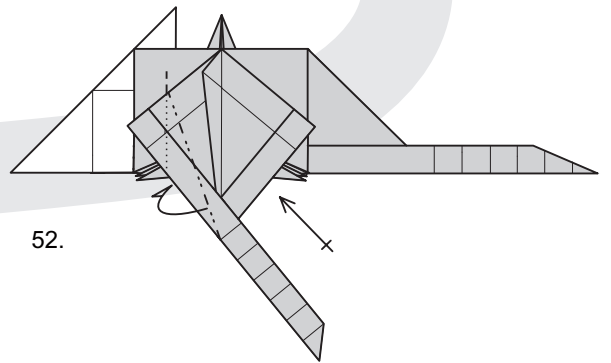

52.

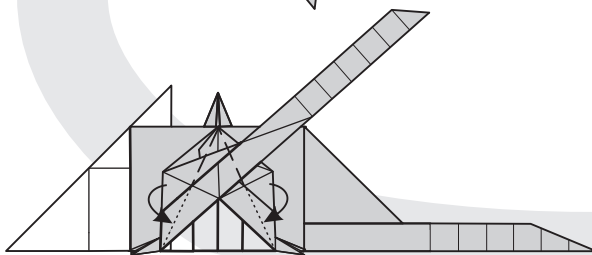

54.

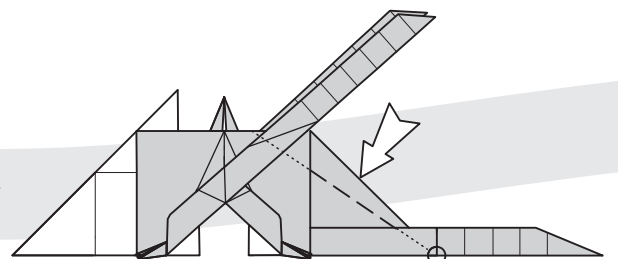

55. Closed sink

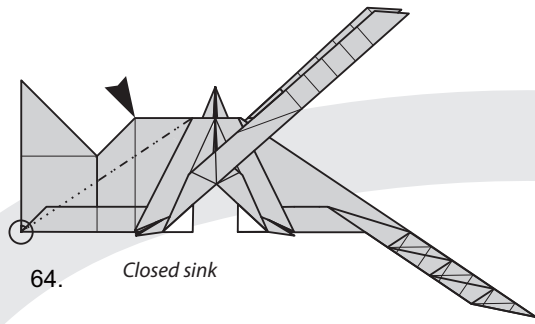

64. *Closed sink*

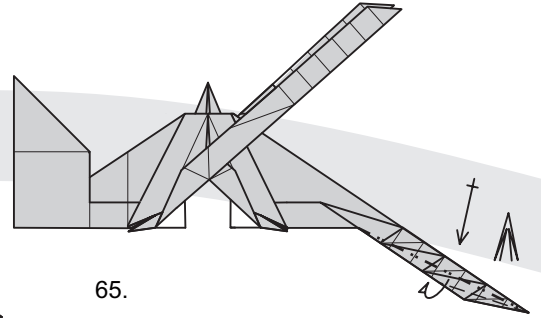

65.

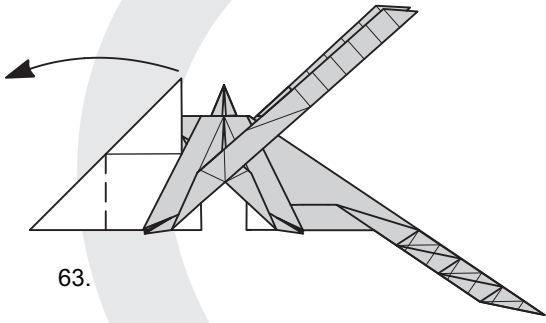

63.

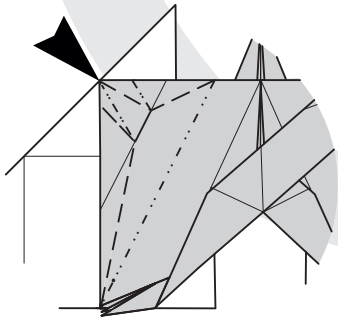

62. *Closed sink*

Powtórz na 3 warstwach.  
Repeat on 3 layers.

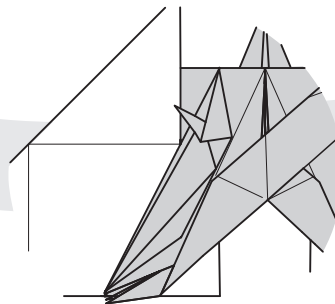

61.

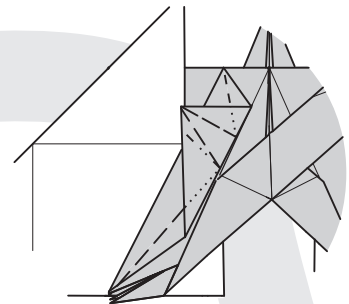

60.

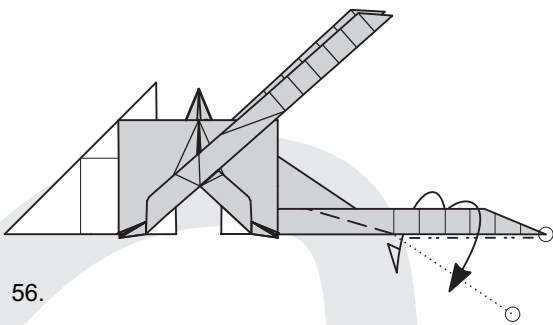

56.

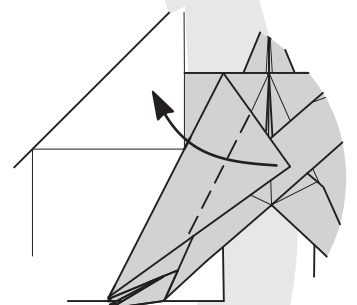

59.

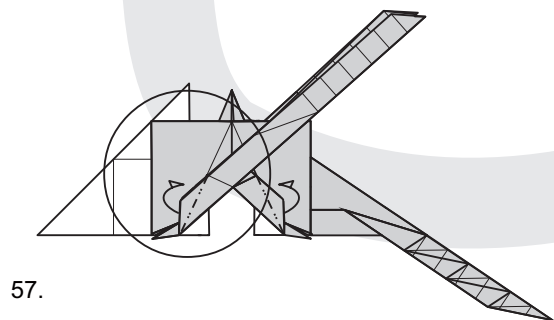

57.

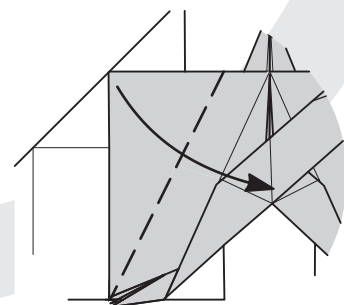

58.



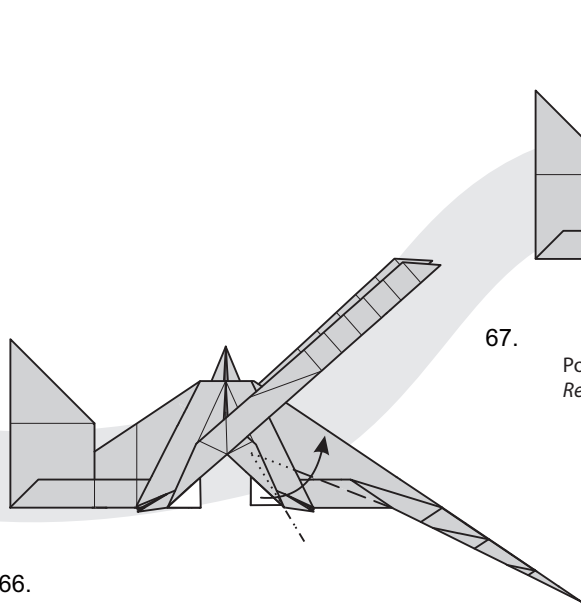

66.

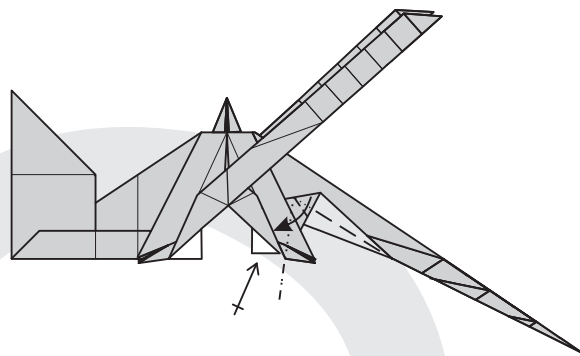

67.

Powtórz kroki 66-67 z tyłu.  
*Repeat steps 66-67 behind.*

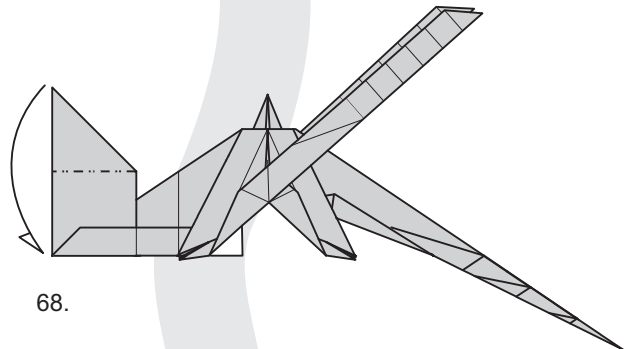

68.

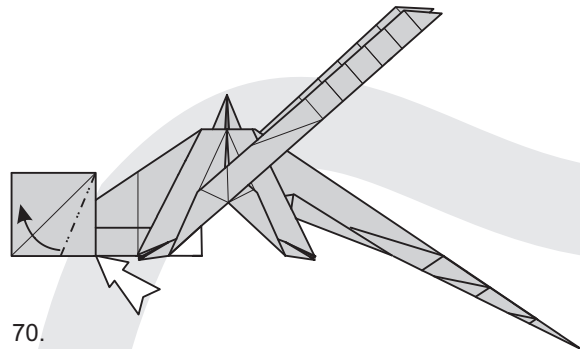

70.

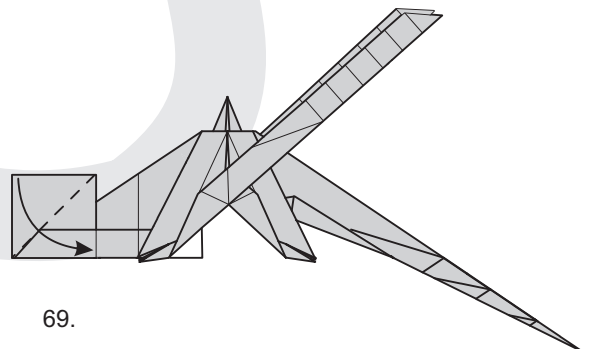

69.

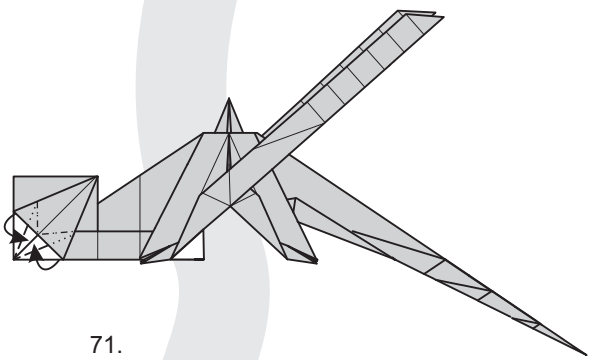

71.

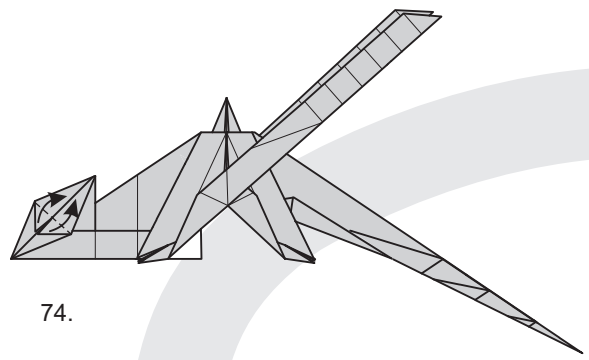

74.

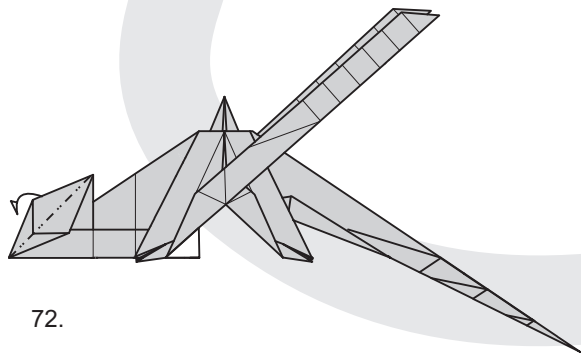

72.

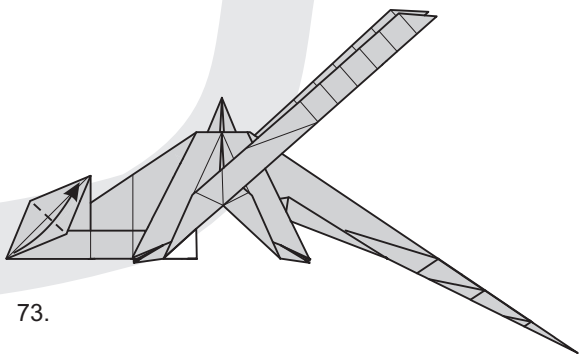

73.

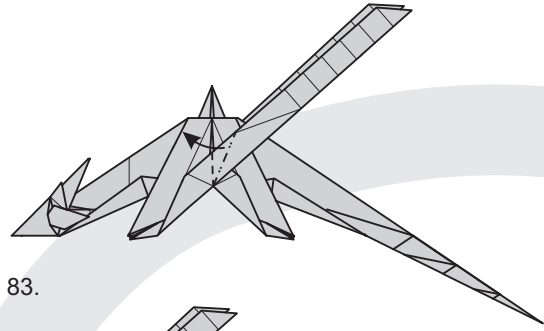

83.

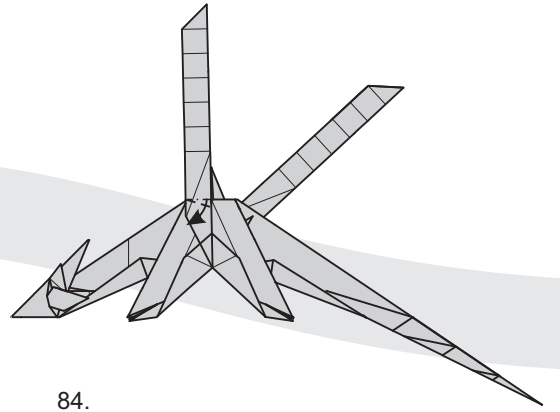

84.

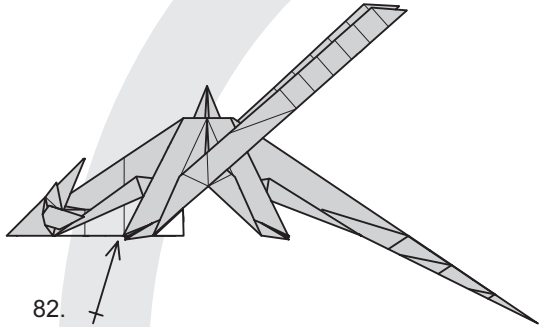

82.

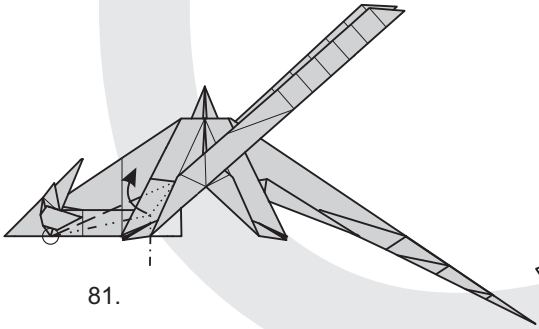

81.

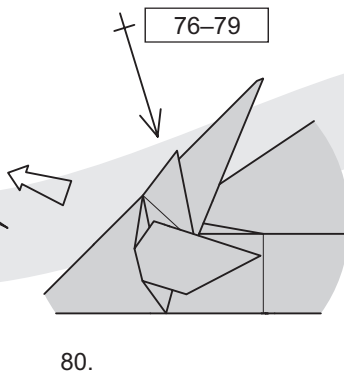

80.

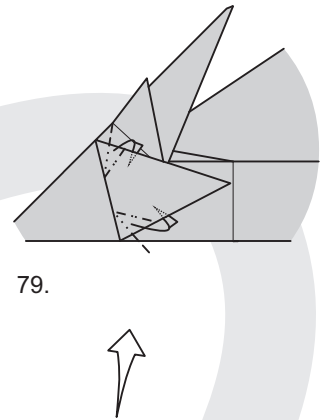

79.

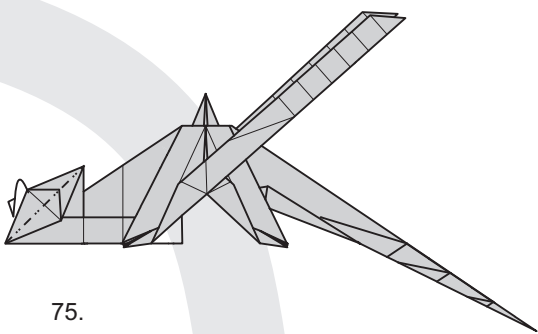

75.

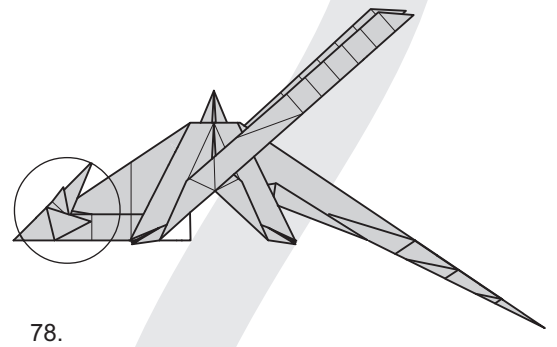

78.

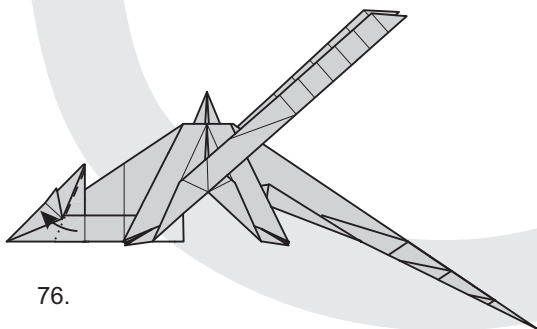

76.

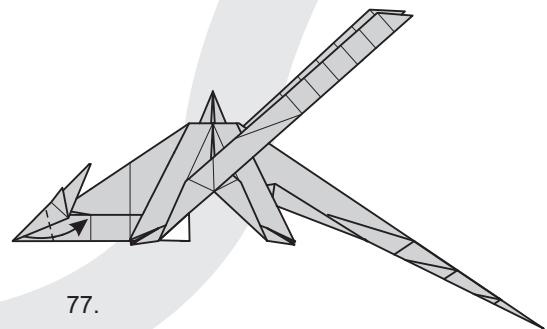

77.

83-85

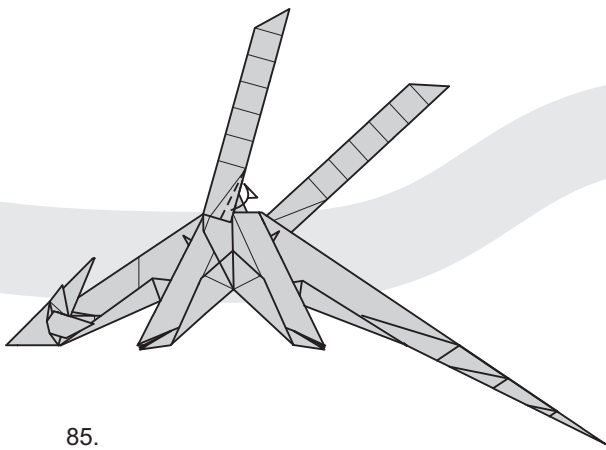

85.

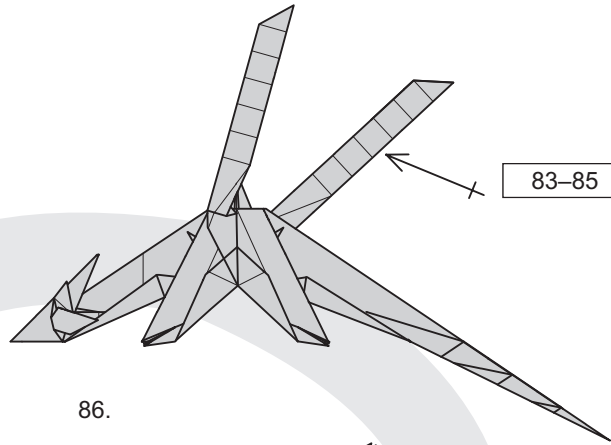

86.

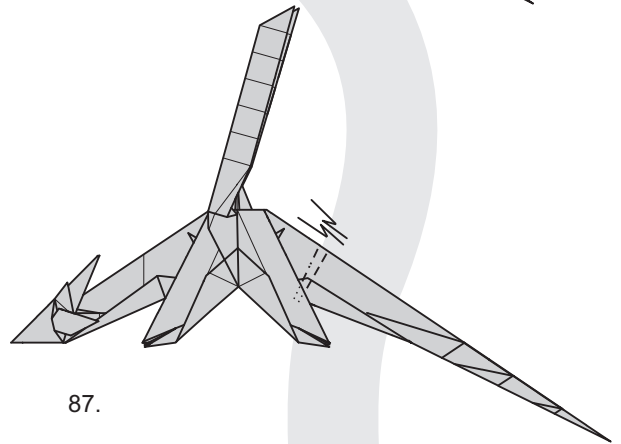

87.

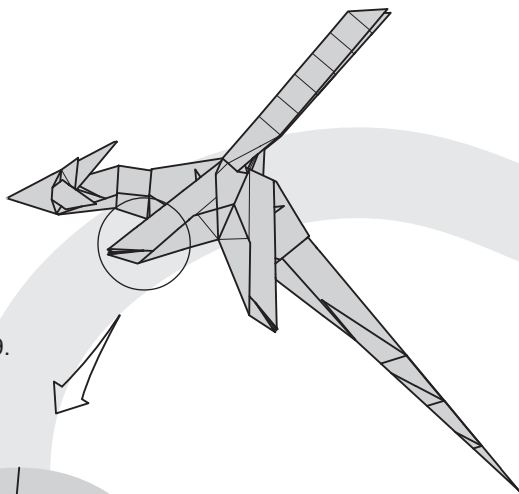

89.

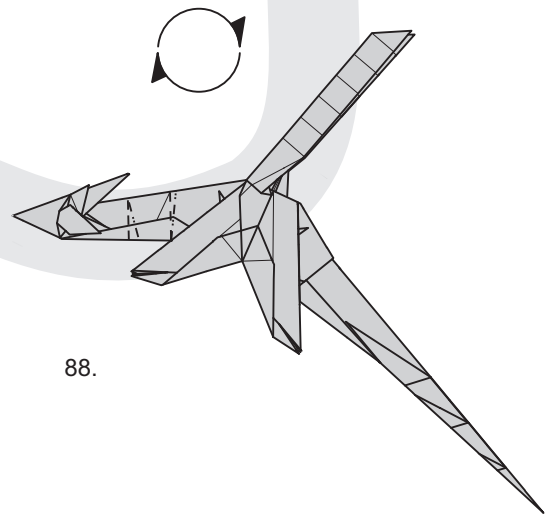

88.

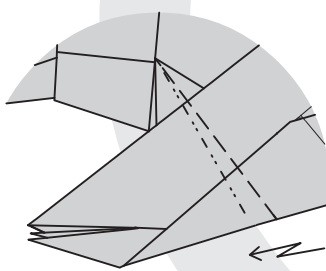

90.

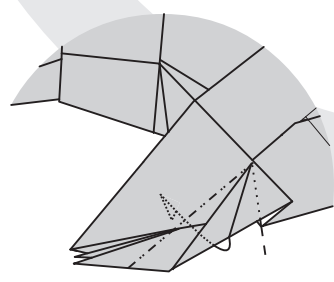

91.

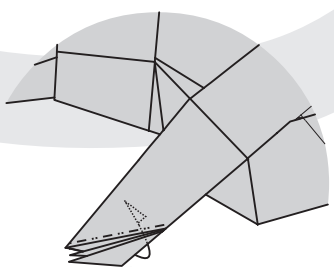

92.

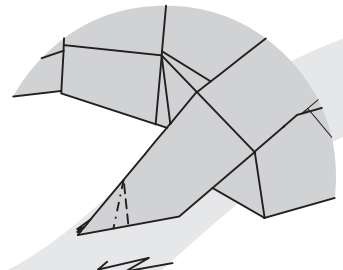

93.

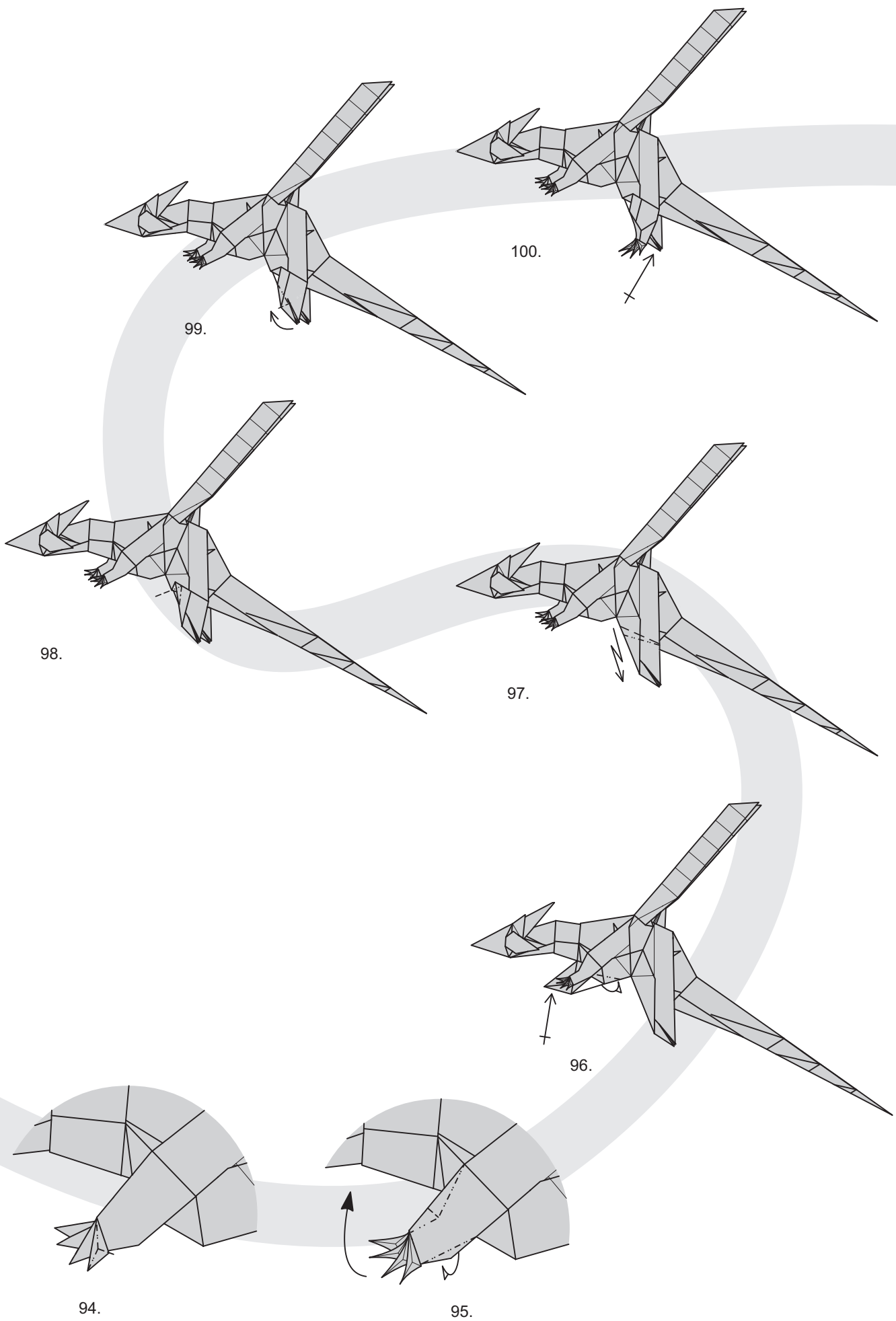

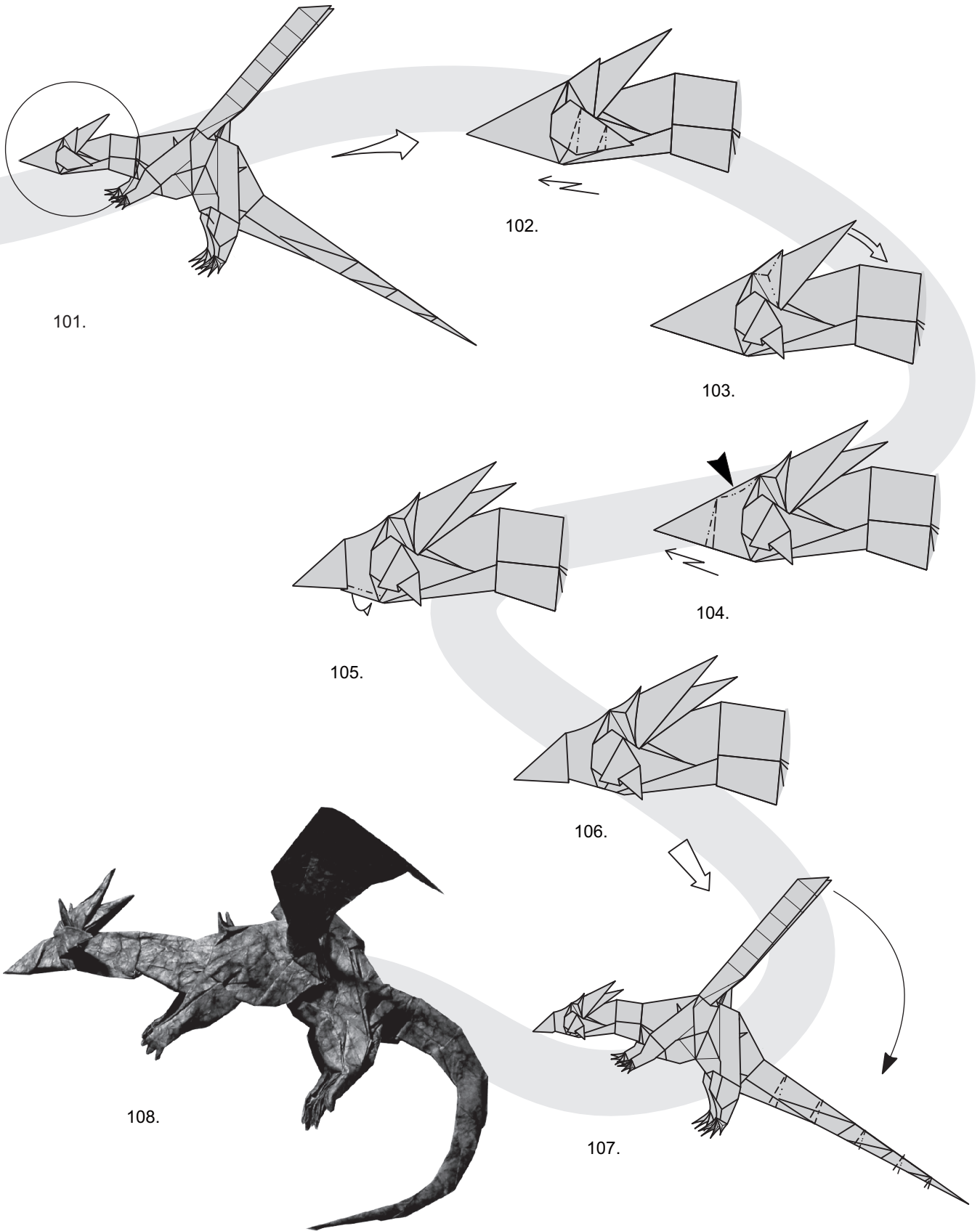

*OrigamiArt™*

Autor zezwala jedynie na korzystanie z modelu w celach niekomercyjnych za pośrednictwem strony [www.origamiart.pl](http://www.origamiart.pl). Zabronione jest publikowanie diagramu i wykorzystywanie zdjęć modelu, na innych stronach www, w publikacjach audio-wizualnych, materiałach drukowanych oraz w formie elektronicznej bez uprzedniej zgody autora. Użycie modelu w celach komercyjnych wymaga podpisania z autorem stosownej umowy licencyjnej zgodnie z obowiązującą ustawą o ochronie praw autorskich. Firmy zainteresowane wykorzystaniem modeli w celach reklamowych, promocyjnych prosimy o kontakt bezpośrednio z autorami na stronie [www.origamiart.pl](http://www.origamiart.pl). Nieprzestrzeganie w/w zasad może być podstawą do dochodzenia należnych praw majątkowych od osób lub instytucji które je naruszyły.

Publishing diagrams or photos of presented models on other websites, in either printed or electronic form, is forbidden, without the authors' explicit permission. Making use of models and/or diagrams published on the website for commercial purposes, requires signing a proper licence agreement with the author, with respect to the copyright protection act in force.